



NAN HUA PRIMARY SCHOOL
PRELIMINARY EXAMINATION 2025
PRIMARY 6

SCIENCE
(BOOKLET A)

Total Time for Booklets A and B: 1 hour 45 minutes

INSTRUCTIONS TO CANDIDATES

1. Write your name, index number and class in the spaces provided below.
2. Do not turn over the page until you are told to do so.
3. Follow all instructions carefully.
4. Answer all questions.
5. Use a 2B pencil to shade your answers on the Optical Answer Sheet (OAS).

Marks Obtained

Booklet A		/ 56
Booklet B		/ 44
Total		/ 100

Name: _____ ()

Form Class: P6 _____

Teaching Group: 6S _____

Date: 20 August 2025

Parent's Signature: _____

This booklet consists of 18 printed pages.

For each question from 1 to 28, four options are given. One of them is the correct answer. Make your choice (1, 2, 3 or 4) and shade your answer on the Optical Answer Sheet. (56 marks)

- 1 The diagram below shows two living things.



baby



fern

Which statement is correct?

- (1) One contains chlorophyll while the other does not.
 - (2) One reproduces by spores while the other lays eggs.
 - (3) One responds to changes around it while the other does not.
 - (4) One takes in carbon dioxide only while the other takes in oxygen only.
- 2 Study the flowchart.

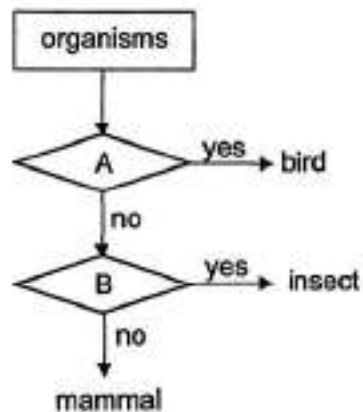

Which row shows the characteristics represented by A and B?

Characteristics		
	A	B
(1)	Has a beak	Has moist skin
(2)	Has feathers	Has six legs
(3)	Has 3 body parts	Lay eggs
(4)	Has wings	Has 3 body parts

0009/02(A)

3 Which of the following is correct for both the cockroach and mosquito?

- (1) Both their young look like the adults.
- (2) Both their life cycles start with an egg.
- (3) The life cycle of cockroach has three stages while mosquito has four stages.
- (4) The young of cockroach lives in water while the young of mosquito lives on land.

4 The diagram shows four different cells.

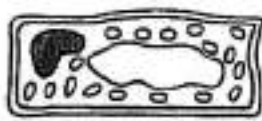

Cell A

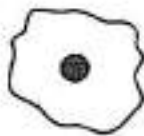

Cell B



Cell C

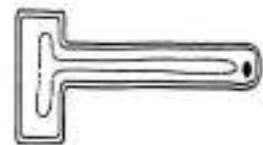

Cell D

Which row classifies the cells correctly?

	Animal Cell	Plant Cell
(1)	B	A, C, D
(2)	A, C	B, D
(3)	B, C	A, D
(4)	B, C, D	A

(Go on to the next page)

0009/02(A)

- 5 Study the fruit.



Below are some items provided:

- A electronic balance
- B ruler
- C beaker of water
- D fan

Which of the following item(s) should be used to determine if the fruit is dispersed by wind?

- (1) A only
 - (2) C only
 - (3) B and D
 - (4) C and D
- 6 The diagrams below show the reproductive systems of a human and a plant.

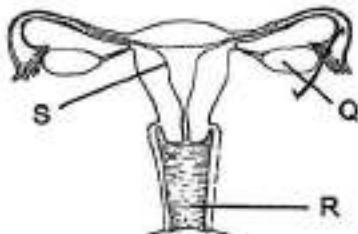

Human reproductive system

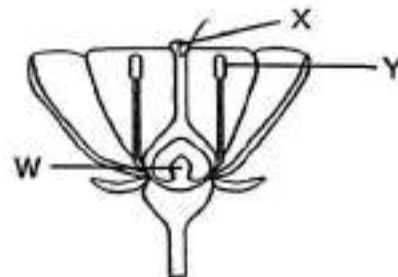

Plant reproductive system

Which parts produce the female reproductive cells?

- (1) Q and W
- (2) Q and Y
- (3) R and X
- (4) S and X

- 7 The diagram shows the human skeletal system.



Which cell part has a similar function to the skeletal system?

- (1) Nucleus
 - (2) Cell wall
 - (3) Cytoplasm
 - (4) Cell membrane
- 8 Plant T grows in a desert. It is able to store air in the leaves.
Bala observed the cells of a leaf of plant T during day and night as shown.

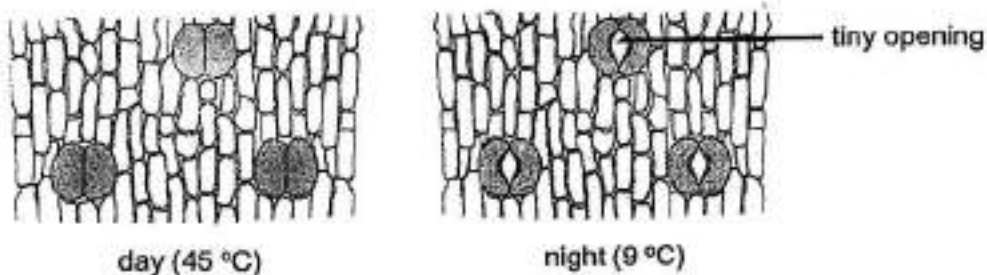

Based on Bala's observations, which statement shows how plant T is adapted for photosynthesis in a desert?

- (1) Plant T only photosynthesises at night.
- (2) Plant T photosynthesises in the day without carbon dioxide.
- (3) Plant T takes in only oxygen in the night and photosynthesises in the day.
- (4) Plant T takes in carbon dioxide in the night and photosynthesises in the day.

(Go on to the next page)

- 9 Ali inflated two balloons to the same size with different methods. He used an air pump to pump air into balloon A and blew air into balloon B.

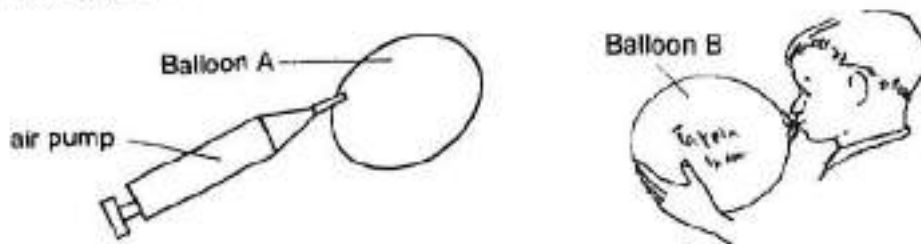

Which is the correct change in the composition of gases inside the balloons?

- (1) There is greater volume of oxygen in A than B.
 (2) There is greater volume of carbon dioxide in A than B.
 (3) Both balloons have greater volume of carbon dioxide than oxygen.
 (4) Both balloons have the same volume of oxygen and carbon dioxide.
- 10 Jane wanted to find out whether the presence of water plants affects the amount of carbon dioxide in the pond. She used the set-up shown.

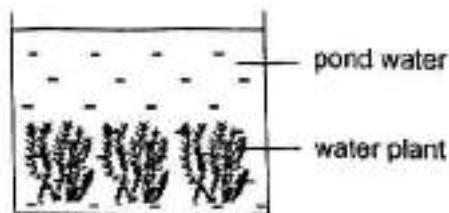

Which of the following set-ups should Jane use as a control for her experiment?

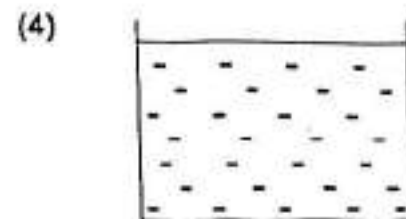
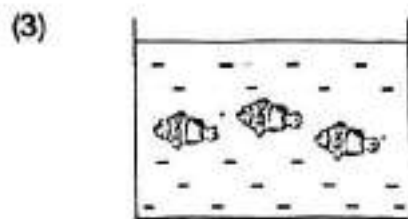
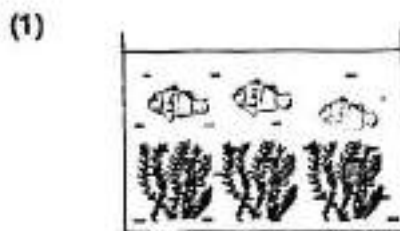

11 The diagram below shows a pond habitat.

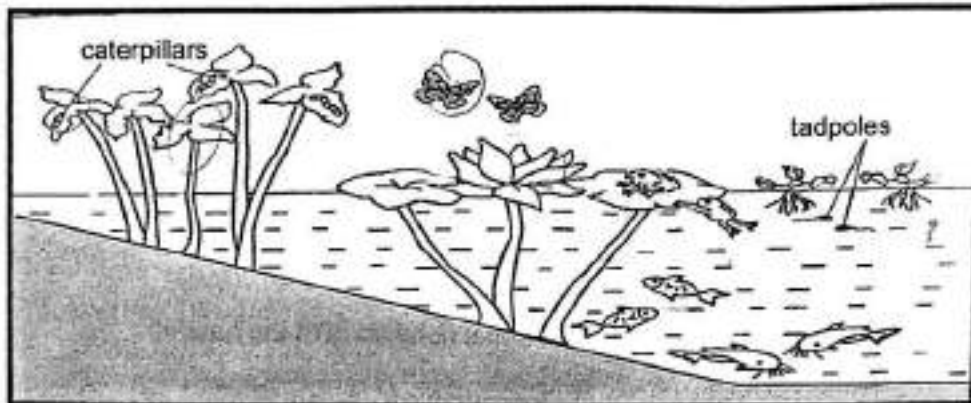

Based on the diagram, which of the following is true?

- (1) There are nine populations in the pond habitat.
- (2) There are seven populations in the pond habitat.
- (3) The aquatic plants form one of the communities in the habitat.
- (4) There are three populations of producers and six populations of consumers.

12 Study the food web below.

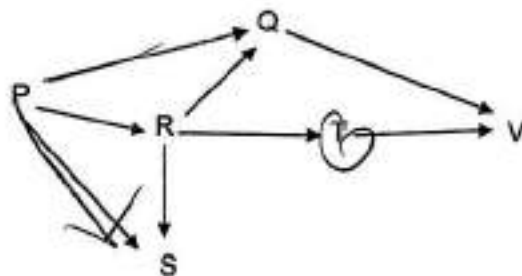

In the colder months of the year, all of organism R will migrate to another location with higher temperature. Which population will be the most affected when organism R are gone?

- (1) P
- (2) Q
- (3) S
- (4) T

(Go on to the next page)

0009/02(A)

- 13 The diagram below shows a group of organisms standing together in their habitat with their young in the centre of the group.



The table states the environmental conditions of the habitat:

Temperature	0 °C
Wind speed	180 km/h

Below are some adaptations and possible reasons stated by some students on how the organisms adapt to the environmental conditions stated above.

Student	Adaptation	Reason
A	Densely packed feathers	Trap air to reduce the heat lost from their body
B	Webbed feet	Swim faster away from their predators
C	Standing closely packed together	Reduce exposure to strong wind and losing heat from their body
D	Standing with the young in the centre of the group	Protect the young from the predators

Which student(s) is/are correct?

- (1) A only
- (2) A and C only
- (3) B and D only
- (4) All of the above

14 What would be the most possible effect after large areas of forests are removed?

- (1) There will be more rainfall.
- (2) There will be less soil erosion.
- (3) There will be more carbon dioxide in the air.
- (4) There will be more oxygen given out to the air.

15 A fisherman pulls a net full of fish onto his boat.

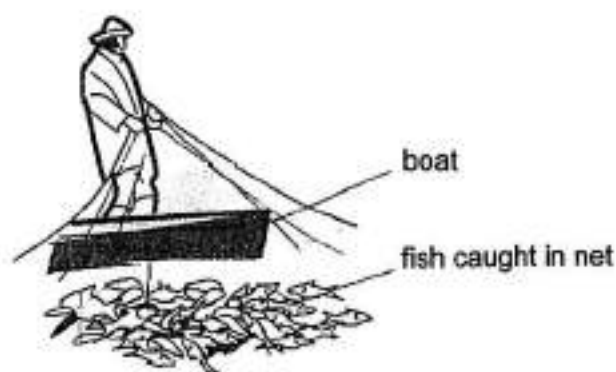

Based on the properties shown, which material is most suitable for making the net?

	Material	Property		
		strong	waterproof	flexible
(1)	A	✓	x	x
(2)	B	x	✓	x
(3)	C	x	✓	✓
(4)	D	✓	x	✓

Key

✓ : yes

x : no

(Go on to the next page)

0009/02(A)

16. Peter poured an equal amount of water into three identical measuring cylinders. Objects, X, Y and Z, were placed in the measuring cylinders as shown in the diagram.

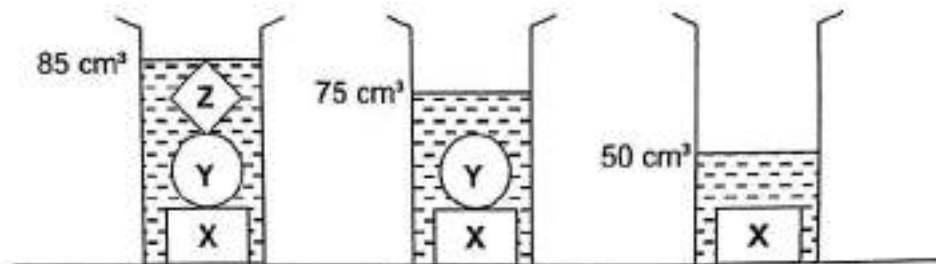

Which statement is correct?

- (1) The mass of object Z is 10 g.
 - (2) The volume of object X is 25 cm³.
 - (3) The volume of object Y is greater than the volume of object Z.
 - (4) The total mass of object X and object Y is greater than the mass of object Z.
17. A container was filled with a substance M. A stopper was then used to seal the air-tight container.

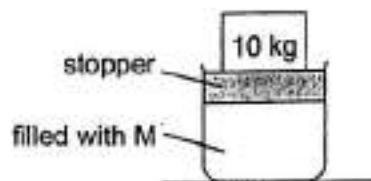

A 10 kg weight was placed on the stopper and the stopper moved downwards. What could be a possible reason for this observation?

- (1) Substance M has mass.
- (2) Substance M occupies space.
- (3) Substance M has no definite shape.
- (4) Substance M has no definite volume.

18 Substances A and B are heated. The graph shows the temperature of A and B over time.

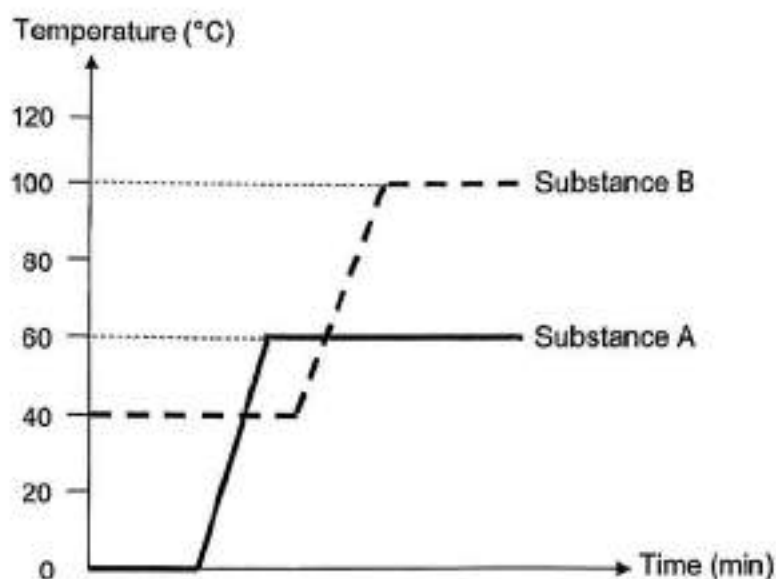

Which row correctly identifies the states of substances A and B at 20°C and 120°C?

	State at 20°C		State at 120°C	
	A	B	A	B
(1)	liquid	not possible to tell	gas	liquid
(2)	liquid	solid	gas	gas
(3)	solid	solid	not possible to tell	gas
(4)	solid	solid	not possible to tell	not possible to tell

(Go on to the next page)

0009/02(A)

- 19 When a bulb was blown in the circuit, one other bulb did **not** light up.

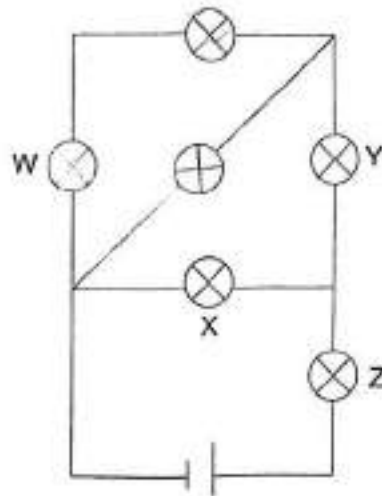

Which bulb was blown?

- (1) W
 - (2) X
 - (3) Y
 - (4) Z
- 20 The diagram shows a motorcyclist getting ready to stop at a traffic light that has turned red.

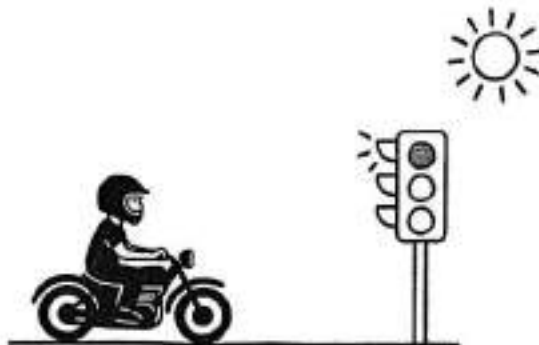

Which statement explains why the motorcyclist is able to see the red light?

- (1) The traffic light gives out light.
- (2) The traffic light is higher than him.
- (3) His eyes reflect light to the traffic light.
- (4) The traffic light reflects light from the sun.

- 21 The diagram shows four objects of the same height.

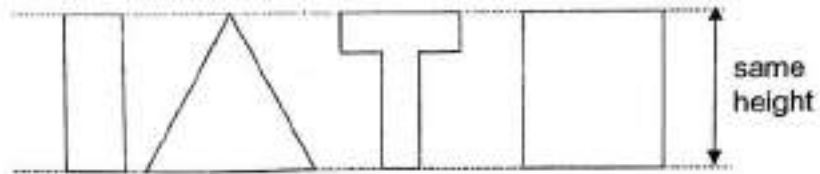

The four objects are placed at different positions between a light source and a screen.

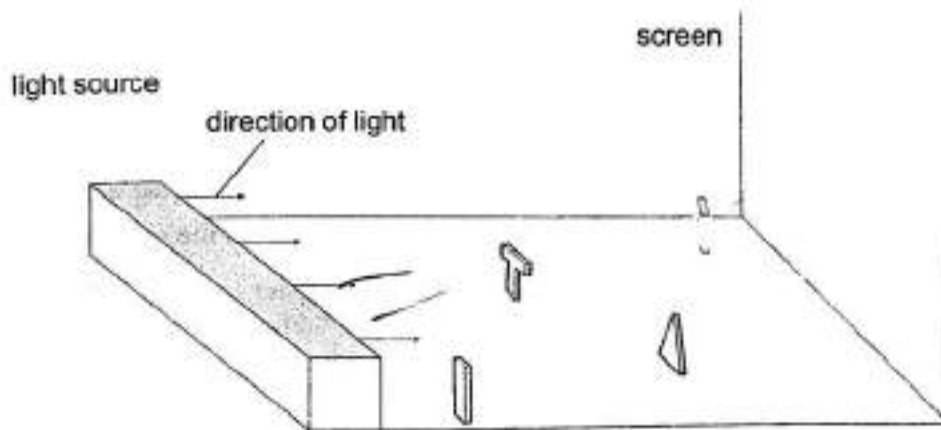

Which of the following shows the shadows formed on the screen?



(Go on to the next page)

- 22 An experiment of four identical beakers containing different amounts of water at different temperatures were placed on the hot plate and then heated up at the same time.

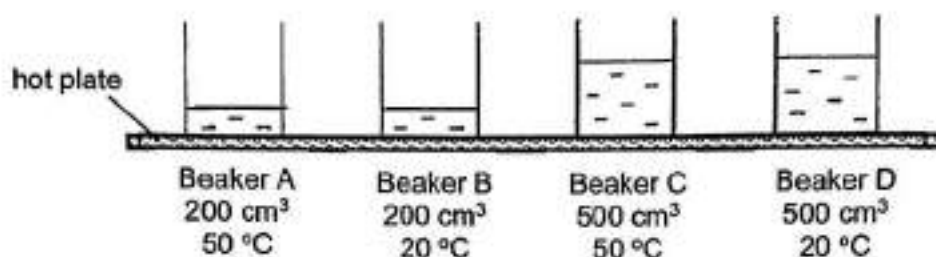

Based on the experiment, which statement is **false**?

- (1) Beaker A will reach the boiling point first when heated.
 - (2) Beaker D will reach the boiling point last when heated.
 - (3) Beaker B has more heat than beaker D at the start of the experiment.
 - (4) Beaker C has more heat than beaker A at the start of the experiment.
- 23 A spring was pulled to position A and then released. The spring moved from A to B and came to a stop at C.

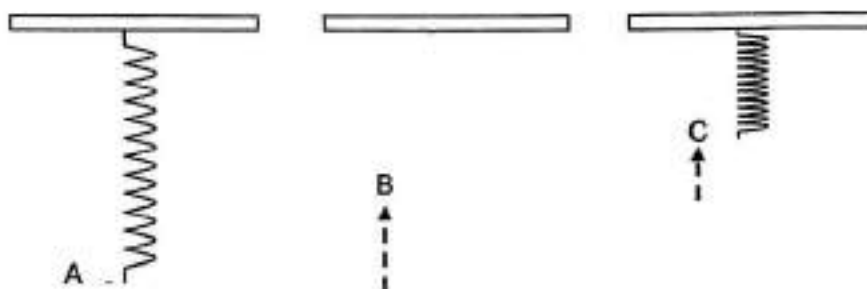

Which row describes the energy of the spring at A, B and C?

	Kinetic energy	Elastic potential energy
(1)	A, B, C	C
(2)	A, B	A
(3)	B	A, B, C
(4)	B	A, B

- 24 Michelle set up an experiment with four rods of the same size but made from different materials, W, X, Y and Z.

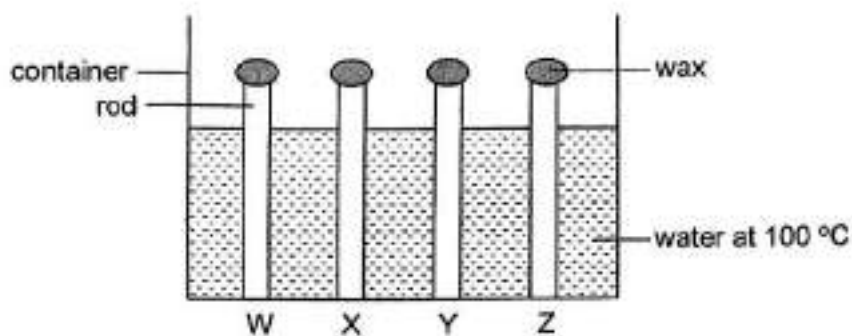

She placed the same amount of wax on the tip of each rod and poured boiling water into the container. She measured and recorded the time taken for the wax on the rods to melt. Her results are plotted in the graph below.

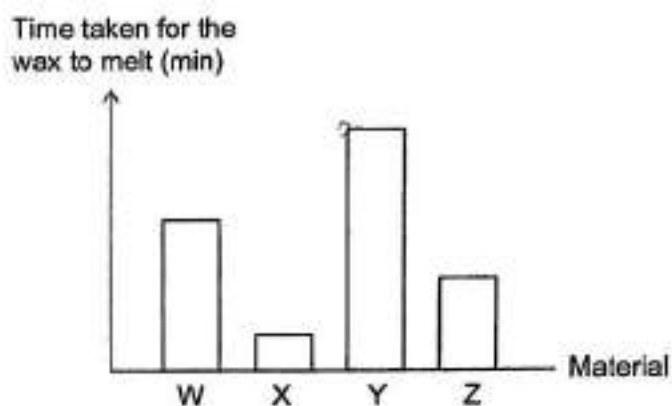

Which material is the most suitable for making boxes to keep food warm for the longest time?

- (1) W
- (2) X
- (3) Y
- (4) Z

(Go on to the next page)

- 25 Li Wen had two similar metal bars PQ and RS. She arranged the two bars in four different ways and the diagrams below show her observations.

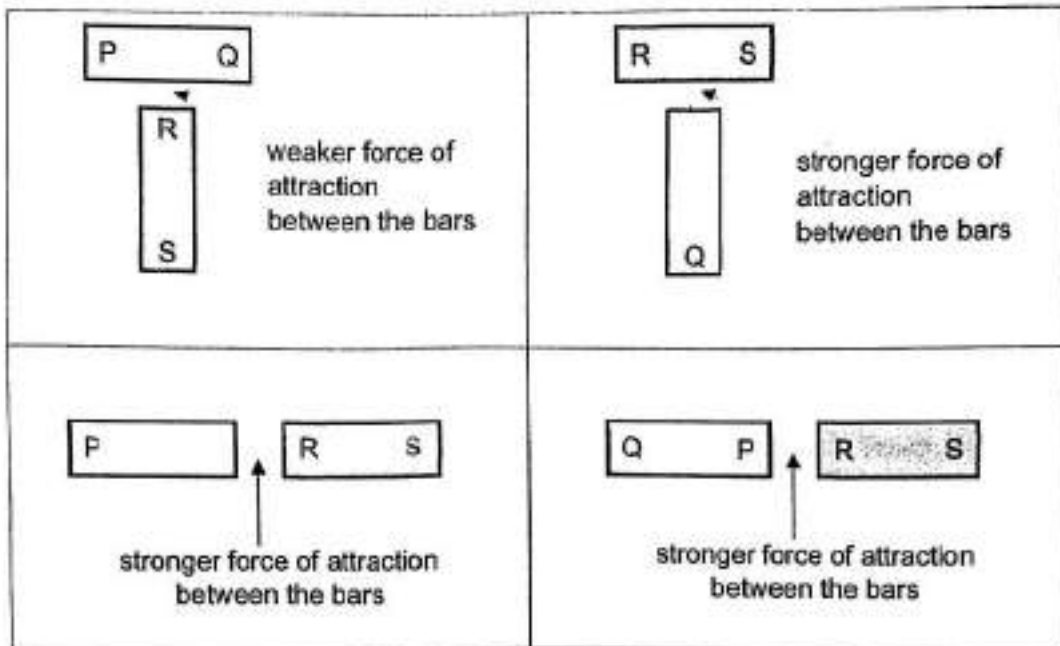

Which of the following best describes the two bars?

	PQ	RS
(1)	magnetic material	magnet
(2)	magnet	magnetic material
(3)	weak magnet	strong magnet
(4)	strong magnet	weak magnet

26 Which of following is **not** an example of a force?

- (1) a boy bouncing a ball
- (2) a pump inflating a balloon
- (3) a roof blocking the sunlight
- (4) a girl switching on the torch

27 Two magnets, C and D, were placed close together with their North poles as shown.

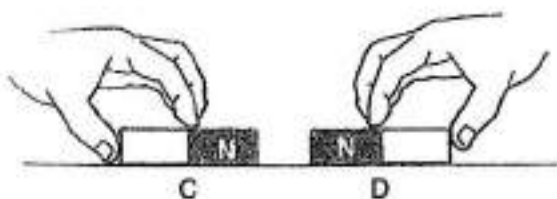

When D was released, it moved along the surface of the floor.

Which row shows the direction of the magnetic force acting on C and the direction of frictional force acting on D?

	Magnetic force acting on C	Frictional force acting on D
(1)	→	←
(2)	←	←
(3)	→	→
(4)	←	→

(Go on to the next page)

0009/02(A)

28 In which circuit would bulb P be the brightest?

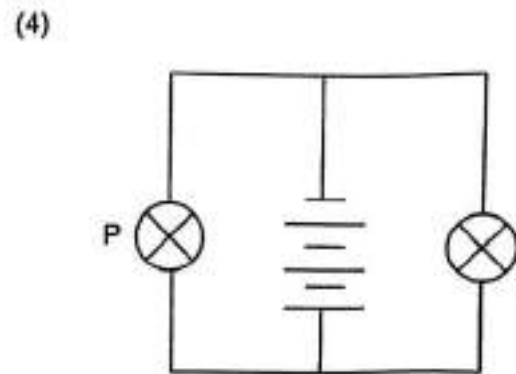
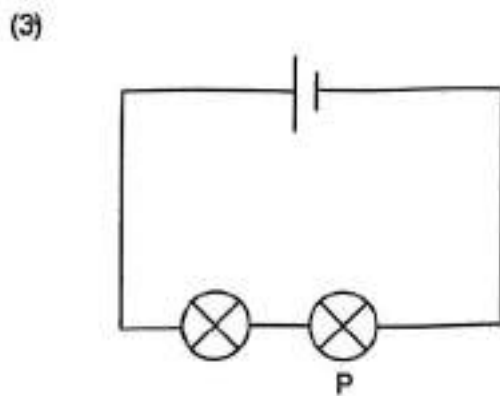
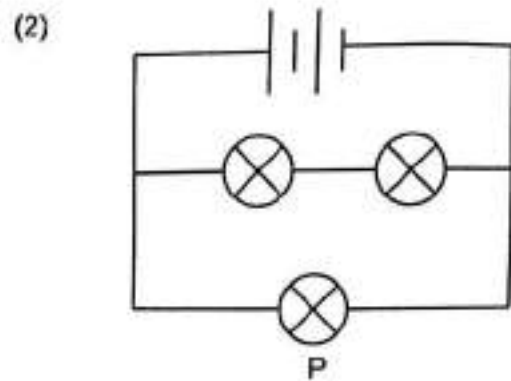
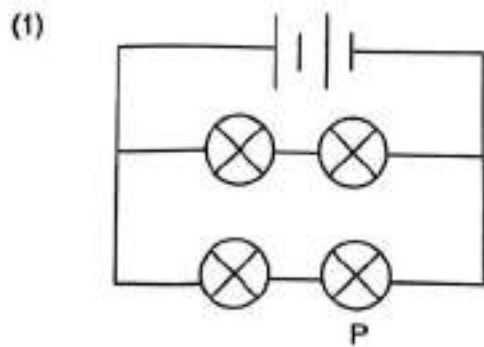

(Go on to Booklet B)

0009/02(A)



NAN HUA PRIMARY SCHOOL
PRELIMINARY EXAMINATION 2025
PRIMARY 6

SCIENCE
(BOOKLET B)

Total Time for Booklets A and B: 1 hour 45 minute:

INSTRUCTIONS TO CANDIDATES

1. Write your name, index number and class in the spaces provided below.
2. Do not turn over the page until you are told to do so.
3. Follow all instructions carefully.
4. Answer all questions.
5. Use dark blue or black ballpoint pen to write your answers in the space provided for each question.
6. Do not use correction fluid/tape or highlighter.

Marks Obtained

Booklet B		/ 44
-----------	--	------

Name: _____ ()

Form Class: P6 _____

Teaching Group: 6S _____

Date: 20 August 2025

Parent's Signature: _____

This booklet consists of 14 printed pages.

000002(A)

For questions 29 to 40, write your answers in this booklet. The number of marks available is shown in brackets [] at the end of each question or part question. (44 marks)

- 29 Linda wanted to find out the colour of flowers that butterflies prefer. She made model flowers using plastic sheets of different colour. She put 10 drops of the same sweetened water in the center of each flower model. The flower models were left in the garden.

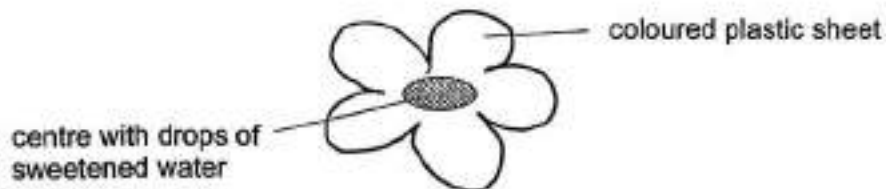

Linda then counted the number of butterflies that visited the model flowers over three hours. The results were recorded in the table below.

Colour of flower	Number of butterflies visiting the flower		
	7 to 8 am	8 to 9 am	9 to 10 am
white	7	4	2
yellow	18	12	8
pink	8	5	8

- (a) Based on Linda's results, which colour did most of the butterflies prefer? Explain [1] your answer.

- (b) State what changes Linda needs to make if she wants to find out the relationship between the size of the flowers and the number of butterflies visiting the flowers. [1]

Score	2
-------	---

0009/02(A)

- 30 The diagram below shows fruit X. Fruit X develops from a flower after fertilisation.



- (a) State the parts of the flower that developed into the fruit and seed after fertilisation. [1]

	Part of the flower before fertilisation	After fertilisation
(i)		fruit
(ii)		seed

- (b) Suggest how the seeds of fruit X are dispersed. [1]

Roy collected some seeds from fruit X and planted them. The table below shows the number of seeds that germinated using seeds collected at various stages of development of fruit X.

Stages of the development of fruit X	Number of seeds germinated
Stage 1: Fruit is pale green, hard and unripe.	0
Stage 2: Fruit is partly yellow and partly pale green, half ripe.	8
Stage 3: Fruit is bright orange, juicy and ripe.	20

- (c) Using the results from Roy's experiment, explain how the characteristics of the unripe fruit benefit plant X. [1]

- (d) State the conditions needed for seeds to germinate. [1]

(Go on to the next page)

Score	4
-------	---

31 The diagram shows the human digestive system.

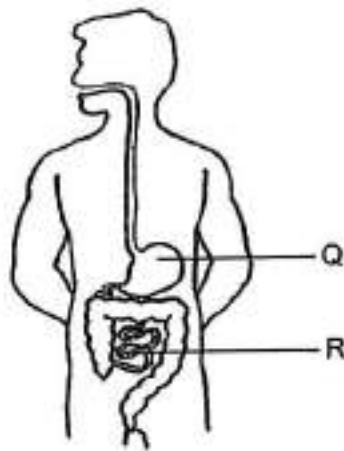

(a) Name organs Q and R. [1]

Q: _____ R: _____

(b) Explain how human systems A and B and the digestive system work together to allow the body to exercise. [2]



Human system A



Human system B

Score	
-------	--

009012(A)

- 32 The diagram shows how substances are transported in a plant. W and X represent different parts of the plant. The arrows represent the movement of substances P and Q.

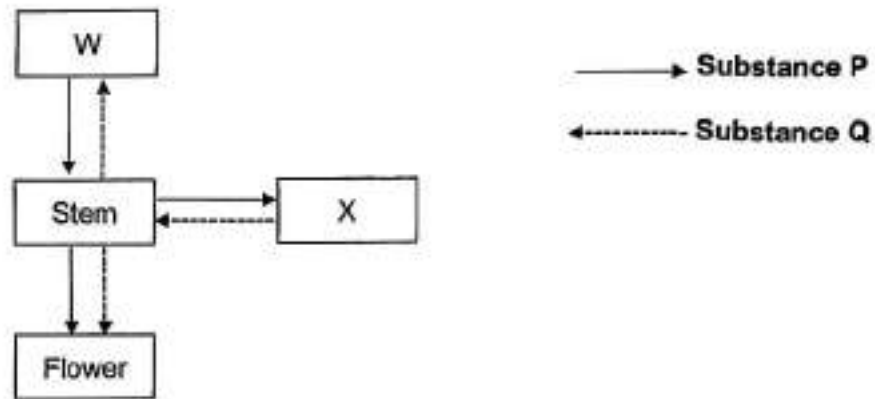

- (a) Name parts W and X. [1]

W: _____ X: _____

- (b) State substances represented by P and Q [1]

P: _____ Q: _____

- (c) Insect S eats its way into the stem of the above plant. This affects the growth of the roots of the plant. Explain why. [2]

(Go on to the next page)

Score	4
-------	---

00902(A)

33 The diagram below shows insect H which feeds on the waste of other animals.



Insect H will roll the waste into balls and bury them deep into the soil where it lives. It lays its eggs into the waste and the eggs will hatch inside the waste.

(a) Give a reason why insect H lays its eggs in animal waste. [1]

(b) Explain how burying animal waste deep into the soil helps insect H survive better. [1]

(c) Insect H usually buries more animal waste than it needs. Plants growing near where insect H lives are healthier when the animal waste undergoes process Q.

(i) Name process Q. [1]

(ii) How does process Q help the plants grow healthily? [1]

(d) David is interested to find out how temperature affects the rate of process Q. State a hypothesis for David's experiment. [1]

Score	5
-------	---

000902(A)

34 Animal X lives on the floor of the sea. It picks up coconut shells and carries them to use.



Animal X carrying shells while moving



Animal X inside shells

- (a) State one benefit for animal X to carry the shells. [1]

- (b) Carrying the shells slows down animal X when it moves. Suggest why carrying the shells could be a disadvantage for animal X. [1]

Ben caught some animal X and two different animals, Y and Z, from the sea. He put animals X and Y in Aquarium A and animals X and Z in Aquarium B. He also put some plants in both aquariums.

He counted the number of animals in the aquariums every week for a month. His results are shown in the graphs below. He did not see any dead animals in the aquariums.

Number of animals

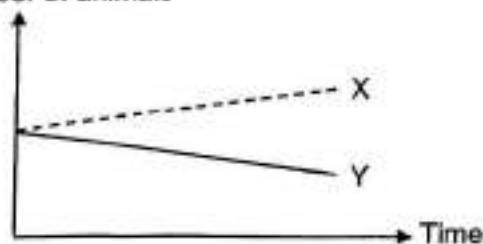

Aquarium A

Number of animals

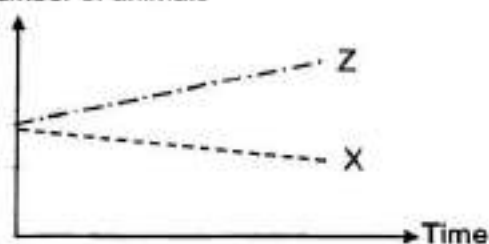

Aquarium B

- (c) Complete the food chain to show the relationship among animals X, Y and Z. [1]



(Go on to the next page)

Score	3
-------	---

000902(A)

- 35 Kumar wanted to investigate the property of three materials, R, S and T. He placed material R in a wooden box as shown in the set-up and recorded the amount of light detected by the light sensor.

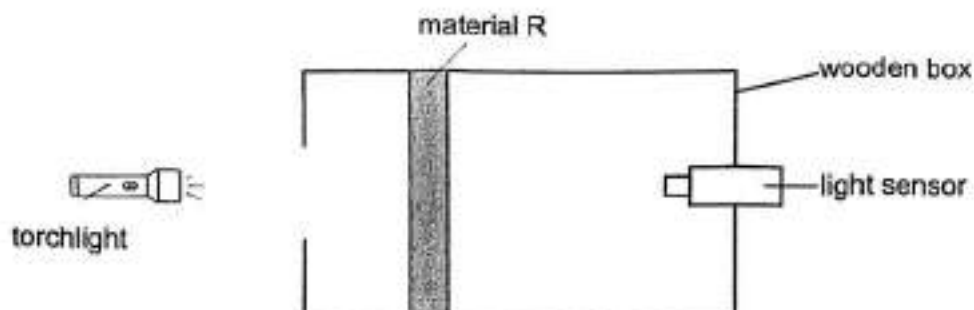

He repeated the experiment with materials S and T of the same thickness. The amount of light detected by the light sensor is recorded in the table.

Material	Amount of light detected (units)
R	0
S	350
T	100

- (a) What property of materials is Kumar investigating? [1]

- (b) A greenhouse is a place where plants are grown. If a farmer wants to build a greenhouse, which material, R, S or T, is the most suitable? Explain your answer. [2]

- (c) To ensure a fair test, the experiment was conducted in a dark room. Explain why. [1]

Score	4
-------	---

000902(A)

36 Sara placed a glass of cold water and ice cubes in a sealed clear box as shown. She then waited for 10 minutes.

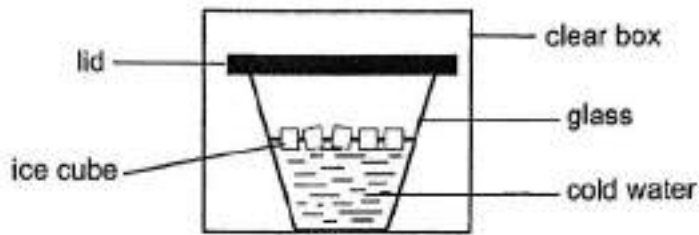

(a) The amount of water vapour in the box decreased after 10 minutes. Explain why. [2]

(b) Sara then placed a glass of hot water in a similar sealed clear box.

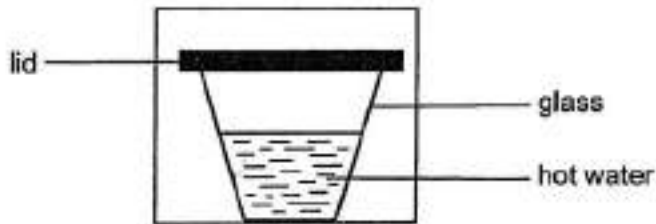

(i) How will the amount of water vapour in the box change after 10 minutes? [1]

(ii) Which diagram shows where water droplets will be formed? Tick (✓) the correct box. [1]

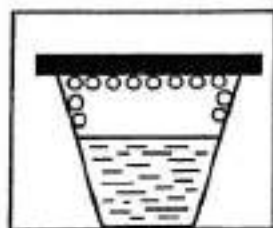

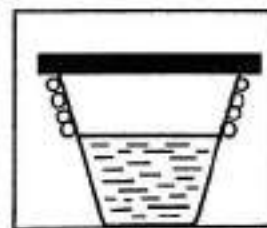

(Go on to the next page)

Score	4
-------	---

37 A wire was coiled around a metal bar in the circuit shown below.

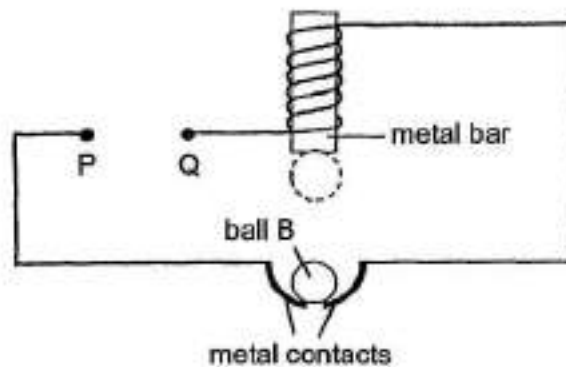

When object Y was connected between points P and Q, ball B moved to the metal bar before dropping back down repeatedly until object Y was removed.

(a) What are the properties of object Y and ball B? Tick (✓) the correct box. [2]

	Does it conduct electricity?		Is it magnetic?	
	Object Y	Ball B	Object Y	Ball B
Yes				
No				
Not possible to tell				

(b) Explain why the ball moved up and down continuously. [2]

Score	4
-------	---

38 (a) What is the difference between heat and temperature?

[1]

(b) Mike had a glass cup with thick wall as shown.

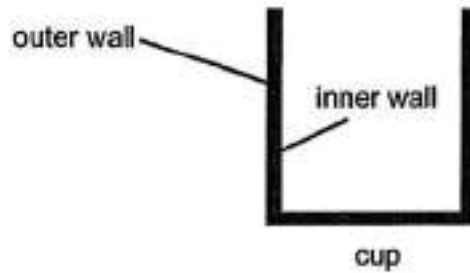

(i) When he poured some hot water into the cup, the inner wall became much hotter than the outer wall. Give a reason for this.

[1]

(ii) When he filled the cup with boiling water, the cup cracked. Explain why.

[1]

(Go on to the next page)

Score	3
-------	---

00902(A)

- 39 Sherwin set up an experiment as shown. Diagram 1 shows that he had pulled the spring back using the handle. Diagram 2 shows that the handle was released and the spring hit the ball. He repeated the experiment for different distances the spring was pulled before being released.

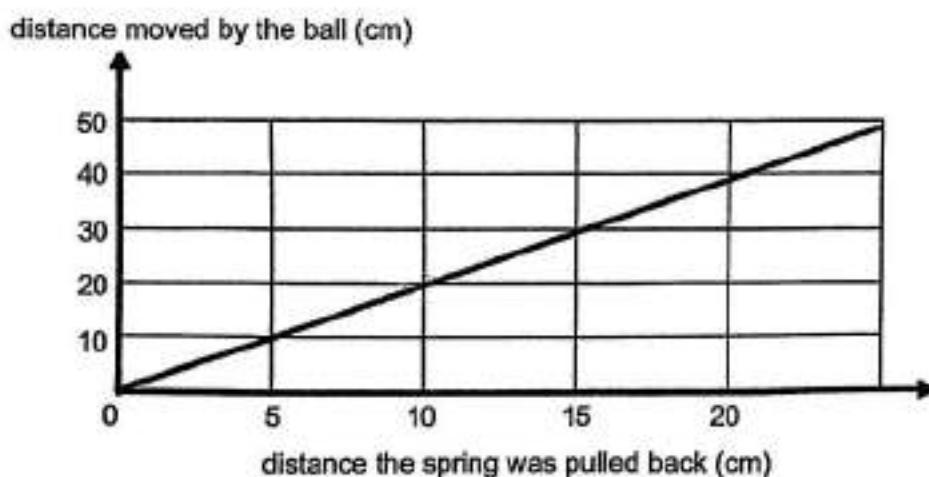
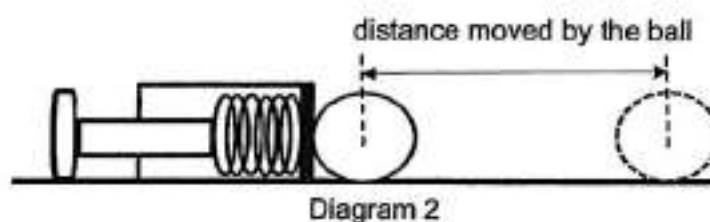
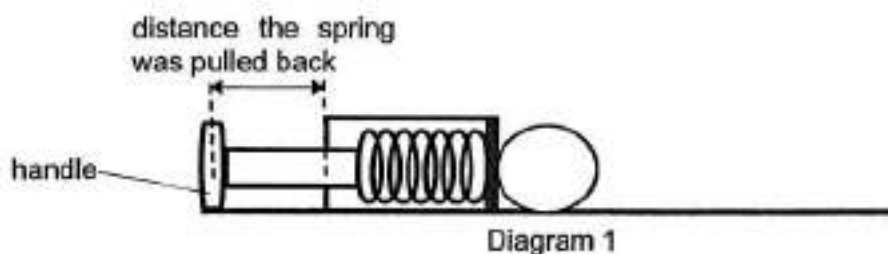

Based on the information given above, answer the following questions.

- (a) How is the distance moved by the ball affected by the distance the spring was pulled back? [1]

(Go on to the next page)

000902(A)

- (b) State the distance moved by the ball when the distance of the spring is pulled back by 10 cm. [1]

- (c) Name the force that is slowing down the moving ball. [1]

- (d) Other than changing the distance the spring is pulled back, state one change that Sherwin could make to the set-up if he wanted the same ball to move a longer distance. Explain why. [1]

(Go on to the next page)

Score	
-------	---

000902(A)

- 40 Diagram 1 shows a piling machine. Diagram 2 shows the hammer falls and hits the pile into the ground.

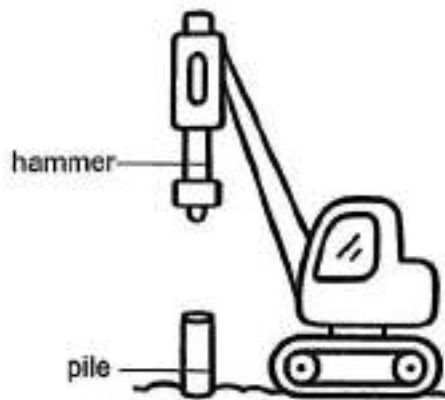
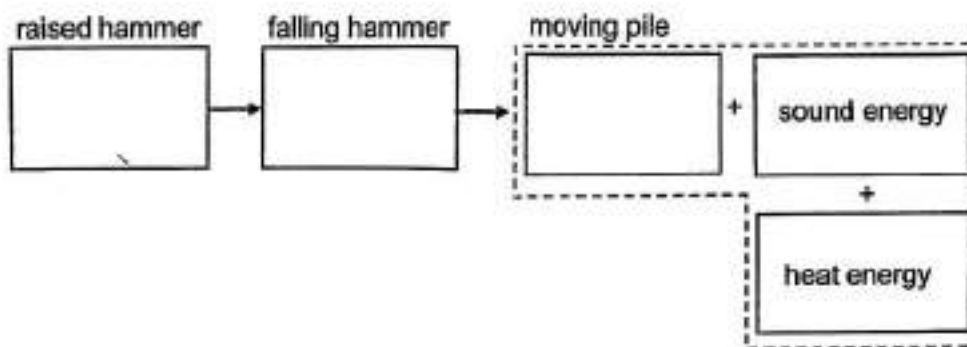

Diagram 1



Diagram 2

- (a) Fill in the boxes to show the energy conversion when the hammer falls and hits the pile into the ground. [2]



- (b) Based on the diagram, suggest a change that could be made to the piling machine so that the pile can be hit deeper into the ground. Explain your answer. [2]

End of Paper

Score	4
-------	---

000902(A)

SCHOOL : NAN HUA PRIMARY SCHOOL
LEVEL : PRIMARY 6
SUBJECT : SCIENCE
TERM : PRELIM 2025

Q1	Q2	Q3	Q4	Q5	Q6	Q7	Q8	Q9	Q10
1	2	3	3	3	1	2	4	1	4
Q11	Q12	Q13	Q14	Q15	Q16	Q17	Q18	Q19	Q20
2	4	2	3	4	3	4	2	1	1
Q21	Q22	Q23	Q24	Q25	Q26	Q27	Q28		
2	3	4	3	2	3	2	4		

NAN HUA PRIMARY SCHOOL
PRELIMINARY EXAMINATION 2025
PRIMARY 6 SCIENCE

Qn	Acceptable Answers
29a	Yellow. It has the <u>most</u> number of butterflies visiting (in the total duration of 3 hours)
29b	Use <u>different size of flowers</u> of the <u>same colour</u> to conduct the experiment
30a	ovary ovule / ovules
30b	By animal. Animal eat the fruit, swallow the seeds and <u>pass the seeds out (in their droppings)</u> / spit out the seeds.
30c	When fruit is unripe, animals are not attracted to it / do not want to eat it. So the seeds will have time to grow and be dispersed only when it is able to germinate / So the seed will be less likely to germinate.
30d	Water/moisture/moist/damp, air/oxygen, warmth/suitable temperature
31a	Q : Stomach R : Small Intestine
31b	Lungs / System A / Respiratory system take in oxygen. Small intestine / Digestive system absorbs digested food into blood. Heart / System B / Circulatory system pumps / transport blood rich in oxygen and digested food to all parts of body to release energy. Carbon dioxide (produced) is transported / pumped to lungs / System A for removal.
32a	W : roots / leaves X : leaves / roots
32b	P : Water (and mineral salts) if W is roots Q : Food / sugar / glucose if X is leaves (vice versa)
32c	Insect S feeds on food from the <u>food-carrying tubes/ destroy the food carrying tubes.</u> <u>So less food produced by leaves will be transported to the roots for life processes.</u>
33a	The young / larva can have food <u>easily/immediately</u> once it hatches
33b	Predators cannot find/spot the young/egg(easily). <u>Alternative answer:</u> Less competition for food as other insect H or young will not find waste. No animals will accidentally step on the waste with the eggs in it
33c (i)	Decomposition
33c (ii)	Decomposers/ Bacteria/ Fungi / Process Q <u>breaks down</u> the waste into simple / simpler substances, which become nutrients/fertilizer for the plant.
33d	<u>Any one:</u> - The higher the temperature, the higher/ lower the rate of decomposition (process Q). - The higher the temperature, the longer/shorter time it takes to decompose (process Q to be completed)

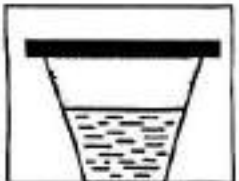
34a	<p><u>Any one</u></p> <ul style="list-style-type: none"> X can stay inside shell to hide from predator. X can stay inside shell so will not be eaten/attacked by predator. X can stay inside shell so will not be spotted by prey when hunting 																								
34b	<p><u>Any one:</u></p> <ul style="list-style-type: none"> - harder to escape quickly from predator - harder to catch prey - uses more energy when moving 																								
34c																									
35a	<p><u>Transparency</u> of the materials</p>																								
35b	<p>C: S E: Material S allows the <u>most</u> light to be detected / pass through. R: The plants will be able to receive most light to make more food / increase rate of photosynthesis.</p>																								
35c	<p><u>Any one:</u></p> <ul style="list-style-type: none"> - To ensure that the torchlight is the only light source which will affect the amount of light detected by the light sensor. - To ensure that there are no other light source affecting the amount of light detected by the light sensor. 																								
36a	<p>The (warmer) water vapour in the box/surrounding will come into contact with cooler outer surface of the glass, loses heat and condenses (to form water droplets).</p>																								
36b (i)	<p>It remained the same / No change</p>																								
36b (ii)																									
37a	<table border="1" data-bbox="223 1400 1220 1657"> <thead> <tr> <th rowspan="2"></th> <th colspan="2">Does it conduct electricity?</th> <th colspan="2">Is it magnetic?</th> </tr> <tr> <th>Object Y</th> <th>Ball B</th> <th>Object Y</th> <th>Ball B</th> </tr> </thead> <tbody> <tr> <td>Yes</td> <td></td> <td>✓</td> <td></td> <td></td> </tr> <tr> <td>No</td> <td></td> <td></td> <td></td> <td></td> </tr> <tr> <td>Not possible to tell</td> <td></td> <td></td> <td>✓</td> <td></td> </tr> </tbody> </table>		Does it conduct electricity?		Is it magnetic?		Object Y	Ball B	Object Y	Ball B	Yes		✓			No					Not possible to tell			✓	
	Does it conduct electricity?		Is it magnetic?																						
	Object Y	Ball B	Object Y	Ball B																					
Yes		✓																							
No																									
Not possible to tell			✓																						
37b	<p><u>Move up</u> The circuit will be closed / electric current can pass through the circuit. The metal bar will be magnetised/ become an electromagnet. The metal bar will attract the metal ball B.</p> <p><u>Drop down</u> The circuit will then be open / electric current cannot pass through the circuit due to the gap between the metal contacts. The metal bar will be demagnetised/no longer be an electromagnet. The metal ball B will drop The cycle repeats.</p>																								

38a	Heat is a form of energy while temperature is the measurement of the degree of hotness or cold of an object.
38b (i)	The inner wall is in direct contact with the hot water. It will gain heat faster/more than the outer wall.
38b (ii)	Due to uneven expansion OR Inner wall will expand more than the outer wall
39a	As the distance the spring was pulled back increases, the distance moved by the ball increases.
39b	20 cm
39c	Frictional force/ Friction
39d	<u>Method 1</u> Add lubricant/oil on the floor/ball Reduce frictional force/friction between the ball and the surface. <u>Method 2</u> Use stiffer spring There will be more elastic spring force on the spring to exert more pushing force on the ball.
40a	Raised hammer: (Gravitational) potential energy Falling hammer: Kinetic energy Moving pile: Kinetic energy
40b	<u>Method any one:</u> - Use a heavier hammer - Hammer of greater mass - Raised hammer to a greater height <u>Explanation:</u> As the hammer is heavier/higher, more (gravitational) potential energy of the hammer is converted to more kinetic energy of the falling hammer, which is transferred/converted to more kinetic energy of the moving pile.